

Optimization of Energy Efficiency in the Process Industries

Madrid
October 20th, 2009

Prof. Dr.-Ing. Bernd Bungert
Beuth Hochschule für Technik Berlin
University of Applied Sciences
Bungert@Beuth-Hochschule.de

1) Motivation

Energy consumption in the Spanish Industry in 2008

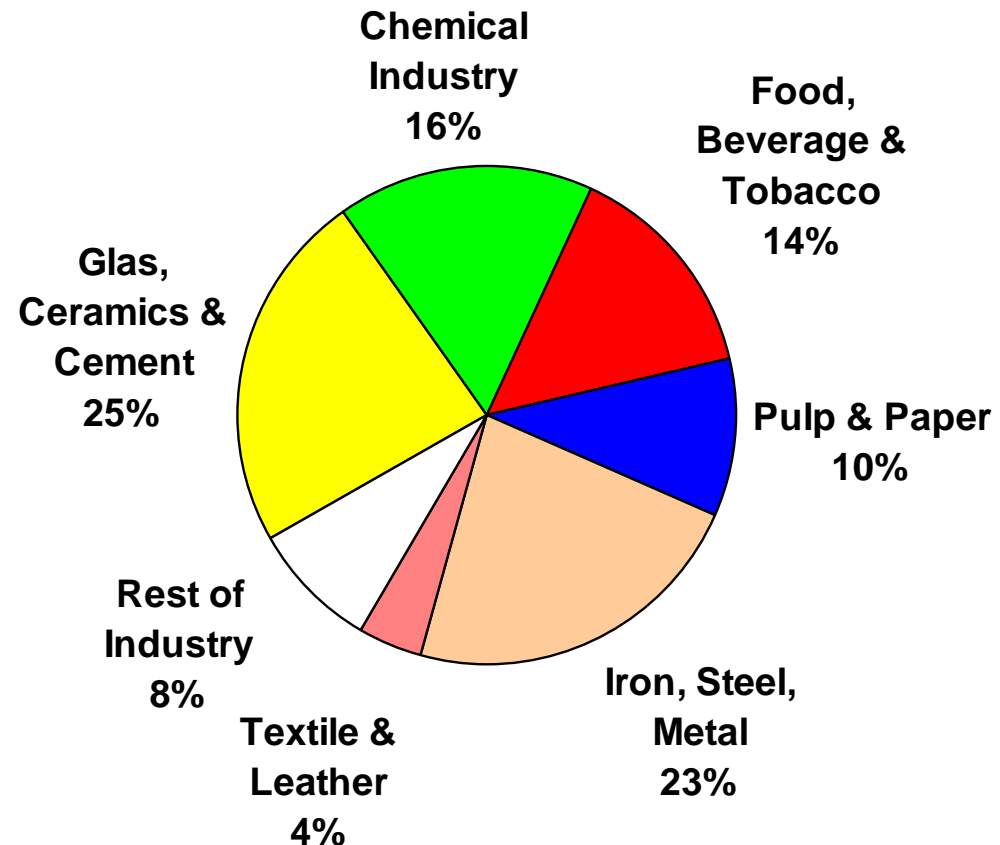

- Main energy sources are fossil fuels
- energy imports account for 80% of energy used (EU average 50%)

1) Motivation

*„The biggest source of oil
can be located within
Germany:
It is energy efficiency“*

*„Die größte Ölquelle liegt unter Deutschland:
Es ist die Energieeffizienz“*

Jürgen Hambrecht, CEO BASF

1) Motivation

*„The biggest source of oil
can be located within
~~Germany:~~
every country itself:
It is energy efficiency“*



1) Motivation and Outline

- 1) Motivation and Outline
- 2) Energy Efficiency: Why?
- 3) Energy Efficiency: How?
- 4) Energy Efficiency: Why else?
- 5) Summary

2) Energy Efficiency: Why?

1) Motivation and Outline

2) Energy Efficiency: Why?

3) Energy Efficiency: How?

4) Energy Efficiency: Why else?

5) Summary

2) Energy Efficiency: Why?

- Estrategia de Ahorro y Eficiencia Energética en España 2004-2012 (E4 2008-2012)
- E.g.: Energy audits for the execution of measures to increase the energy efficiency
- The Spanish state takes up to 75% of the costs for such audits

3) Energy Efficiency: How?

- 1) Motivation and Outline
- 2) Energy Efficiency: Why?
- 3) Energy Efficiency: How?
- 4) Energy Efficiency: Why else?
- 5) Summary

3) Energy Efficiency: How?

Fields of Optimization

- **Process technology**

- Heat integration
- „Waste heat recovery“
- Thermal & Mechanical process engineering
- Reaction engineering
- Process intensification

- **Component Efficiency**

- Facilities for Heating and Cooling
- Heat Exchangers
- Dryers
- Mills
- Agitators, Kneaders
- Pumps
- Compressors, vacuum pumps
- Lifting, conveying and transport
- Motors and Drives
- Lifecycle costs / total cost of ownership

- **Usage of energy sources**

- cogeneration
- steam (pressure levels)
- condensate return and reuse
- water (river, city, cooled)
- compressed air
- natural gas

- **Production buildings**

- Insulation
- HVAC (heating, ventilation & air conditioning)
- lighting

- **Process control and operation**

- Automation
- Production planning
- Information management
- Energy management

- **Management**

- Energy contracting
- New methods for project financing

- Process technology

- Heat integration
- „Waste heat recovery“
- Thermal & Mechanical process engineering
- Reaction engineering
- Process intensification

- Component Efficiency

- Facilities for Heating and Cooling
- Heat Exchangers
- Dryers
- Mills
- Agitators, Kneaders
- Pumps
- **Compressors**, vacuum pumps
- Lifting, conveying and transport
- Motors and Drives
- **Lifecycle costs / total cost of ownership**

- Usage of energy sources

- cogeneration
- steam (pressure levels)
- condensate return and reuse
- water (river, city, cooled)
- **compressed air**
- natural gas

- Production buildings

- Insulation
- HVAC (heating, ventilation & air conditioning)
- lighting

- Process control and operation

- Automation
- Production planning
- Information management
- Energy management

- Management

- Energy contracting
- New methods for project financing

3) Energy Efficiency: How?

**Example 1: Component efficiency and usage of energy sources:
compressed air**

Results of EU studies imply that **pressurized** air **plants** in the EU consume 80 billion kWh per year (80,000,000,000 kWh/a). This equals **10%** of the **industrial power consumption** in the EU.

$$w_{12} = \frac{\kappa}{\kappa-1} p_1 v_1 \left[\left(\frac{p_2}{p_1} \right)^{\frac{\kappa-1}{\kappa}} - 1 \right] = h_2 - h_1 = cp(T_2 - T_1)$$

$$w_{12} \cong 3,5 p_1 v_1 \left[\left(\frac{p_2}{p_1} \right)^{0,3} - 1 \right] \quad w_{12} = K \left[\left(\frac{p_2}{p_1} \right)^{0,3} - 1 \right] = cp(T_2 - T_1)$$

Thermodynamics of compressed air

3) Energy Efficiency: How?

Example 1: compressed air

$$w_{12} = \frac{\kappa}{\kappa-1} p_1 v_1 \left[\left(\frac{p_2}{p_1} \right)^{\frac{\kappa-1}{\kappa}} - 1 \right] = h_2 - h_1 = cp(T_2 - T_1)$$

$$w_{12} \cong 3,5 p_1 v_1 \left[\left(\frac{p_2}{p_1} \right)^{0,3} - 1 \right] \quad w_{12} = K \left[\left(\frac{p_2}{p_1} \right)^{0,3} - 1 \right] = cp(T_2 - T_1)$$

~~Thermodynamics of compressed air~~

3) Energy Efficiency: How?

Example 1: compressed air

$$w_{12} = \frac{\kappa}{\kappa-1} p_1 v_1 \left[\left(\frac{p_2}{p_1} \right)^{\frac{\kappa-1}{\kappa}} - 1 \right] = h_2 - h_1 = cp(T_2 - T_1)$$
$$w_{12} \cong 3,5 p_1 v_1 \left[\left(\frac{p_2}{p_1} \right)^{0,3} - 1 \right] \quad w_{12} = K \left[\left(\frac{p_2}{p_1} \right)^{0,3} - 1 \right] = cp(T_2 - T_1)$$



$$P = \dot{m} w_{12} = \dot{m} * f \left(\frac{p_2}{p_1} \right)$$
$$(T_2 - T_1) = f \left(\frac{p_2}{p_1} \right)$$

- The specific work or **power** needed when multiplied with mass flow rate is a **function of the pressure ratio**.
- The **temperature increase** is a function of **pressure ratio**

3) Energy Efficiency: How?

Example 1: compressed air

$$w_{12} = \frac{\kappa}{\kappa-1} p_1 v_1 \left[\left(\frac{p_2}{p_1} \right)^{\frac{\kappa-1}{\kappa}} - 1 \right] = h_2 - h_1 = cp(T_2 - T_1)$$

$$w_{12} \cong 3,5 p_1 v_1 \left[\left(\frac{p_2}{p_1} \right)^{0,3} - 1 \right] \quad w_{12} = K \left[\left(\frac{p_2}{p_1} \right)^{0,3} - 1 \right] = cp(T_2 - T_1)$$

Power ratio
[%]

$$P = \dot{m} w_{12} = \dot{m} * f \left(\frac{p_2}{p_1} \right)$$

$$(T_2 - T_1) = f \left(\frac{p_2}{p_1} \right)$$

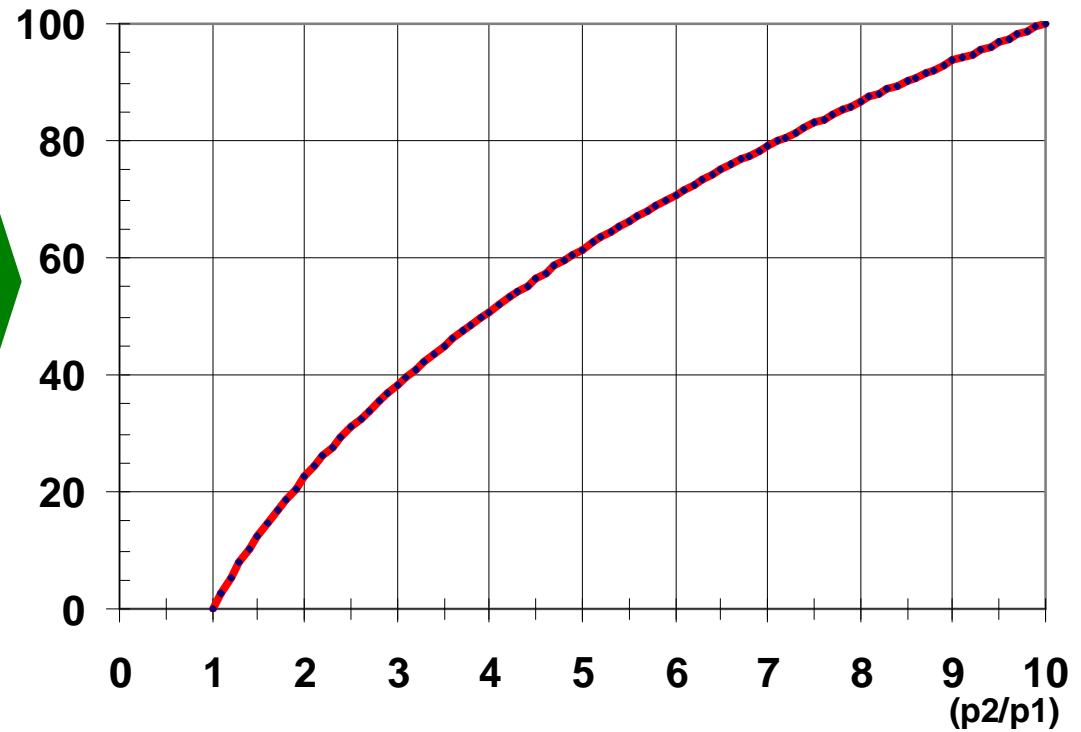

3) Energy Efficiency: How?

Example 1: compressed air

$$w_{12} = \frac{\kappa}{\kappa-1} p_1 v_1 \left[\left(\frac{p_2}{p_1} \right)^{\frac{\kappa-1}{\kappa}} - 1 \right] = h_2 - h_1 = cp(T_2 - T_1)$$

$$w_{12} \cong 3,5 p_1 v_1 \left[\left(\frac{p_2}{p_1} \right)^{0,3} - 1 \right] \quad w_{12} = K \left[\left(\frac{p_2}{p_1} \right)^{0,3} - 1 \right] = cp(T_2 - T_1)$$

Power ratio
[%]

$$P = \dot{m} w_{12} = \dot{m} * f \left(\frac{p_2}{p_1} \right)$$

$$(T_2 - T_1) = f \left(\frac{p_2}{p_1} \right)$$

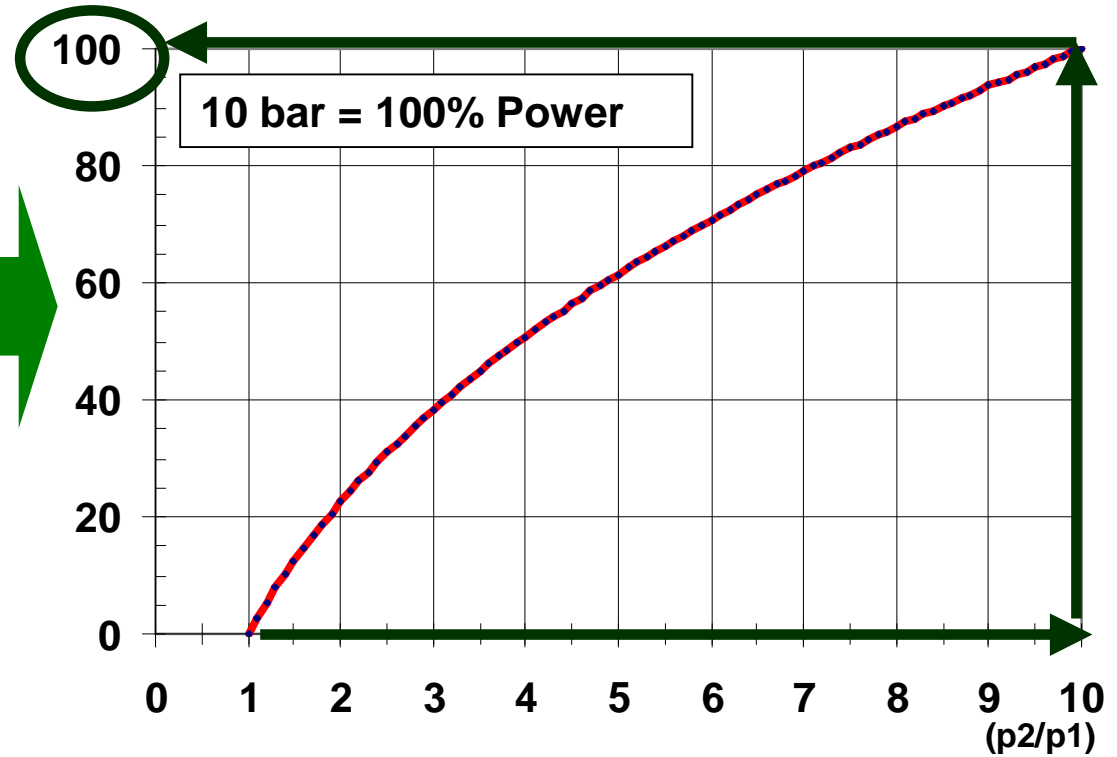

3) Energy Efficiency: How?

Example 1: compressed air

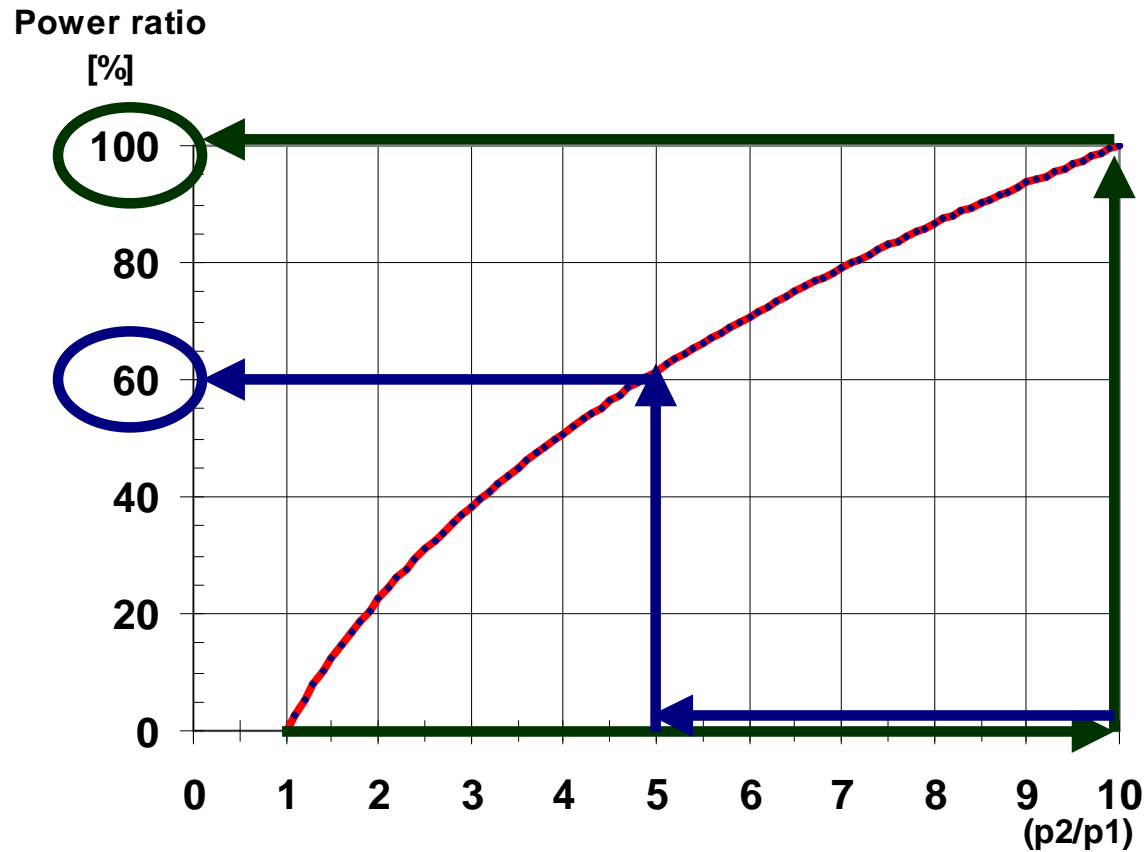

Example:

Produce compressed air with 10 bar: $p_2/p_1 = 10$, energy needed = 100%

Reduce (throttle) pressure to 5 bar, energy equivalent = 60%

3) Energy Efficiency: How?

Example 1: compressed air

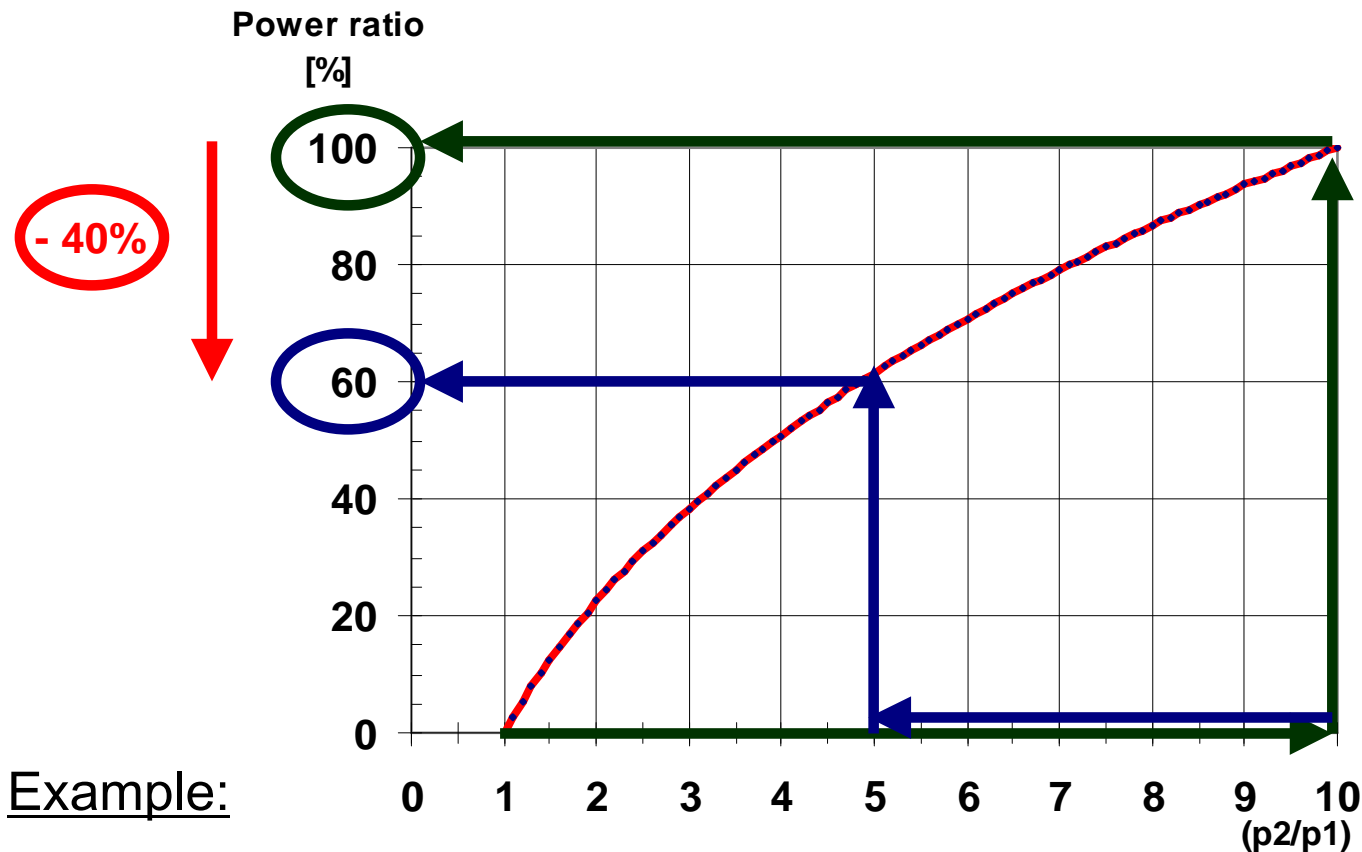

Produce compressed air with 10 bar: $p_2/p_1 = 10$, energy needed = 100%
Reduce (throttle) pressure to 5 bar, energy equivalent = 60%

= „Destroy“ 40% of energy input!

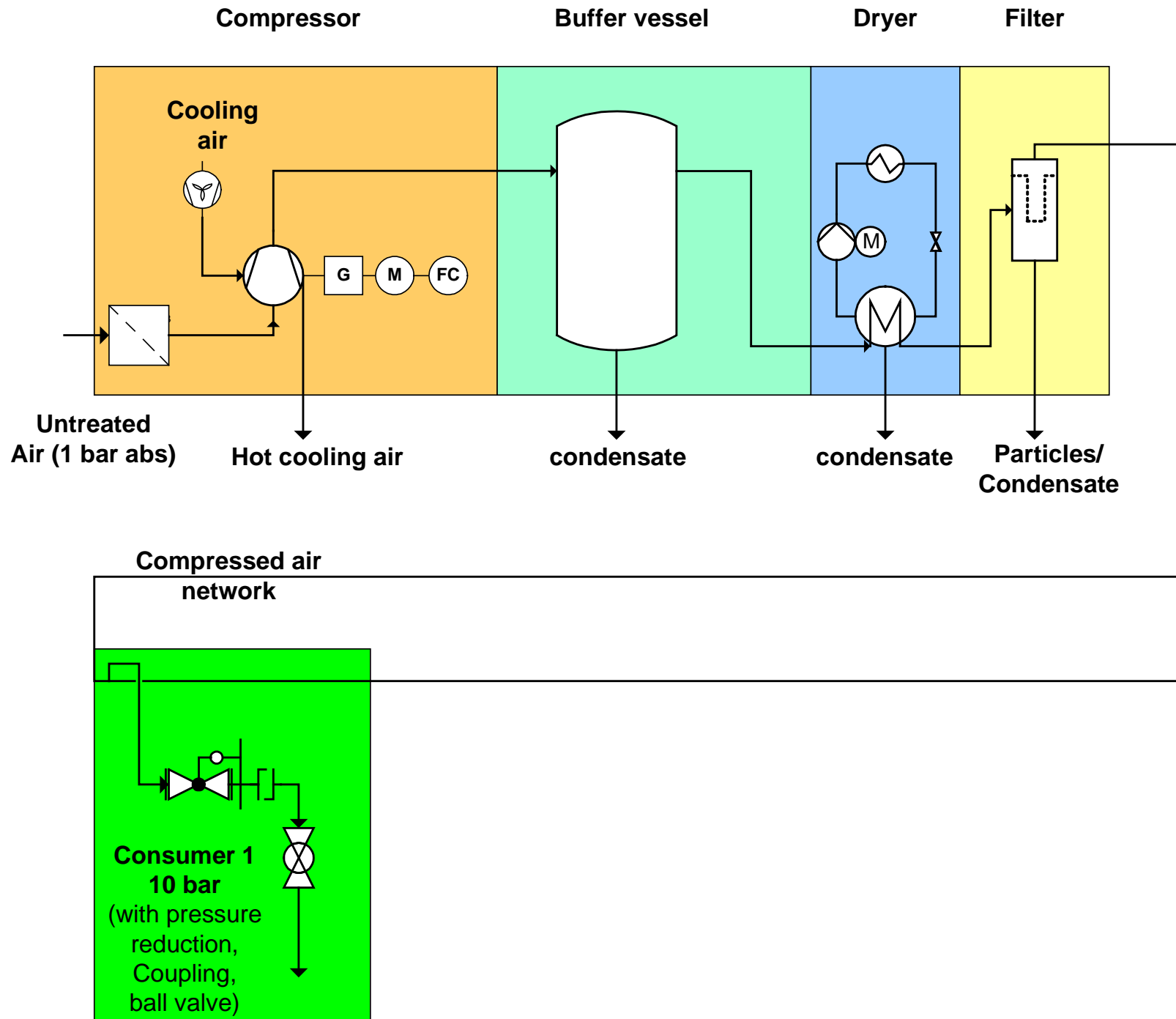

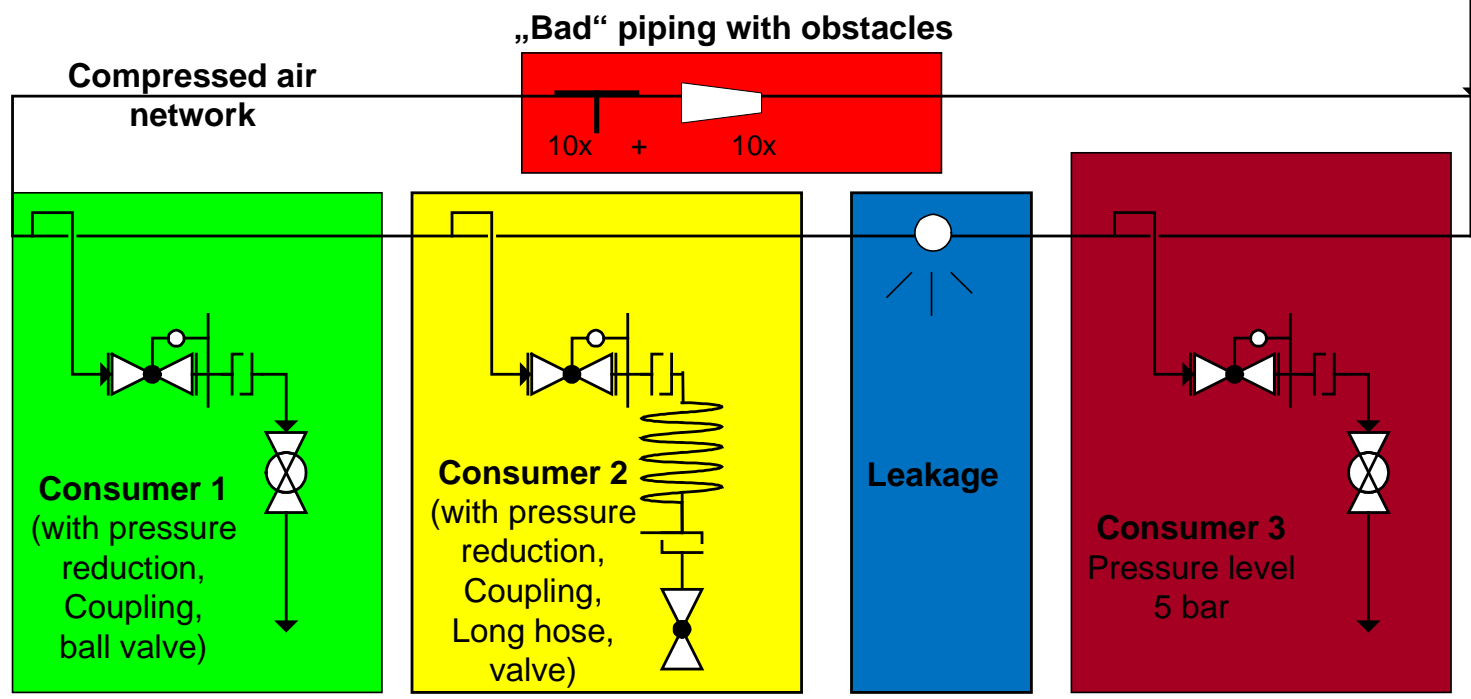
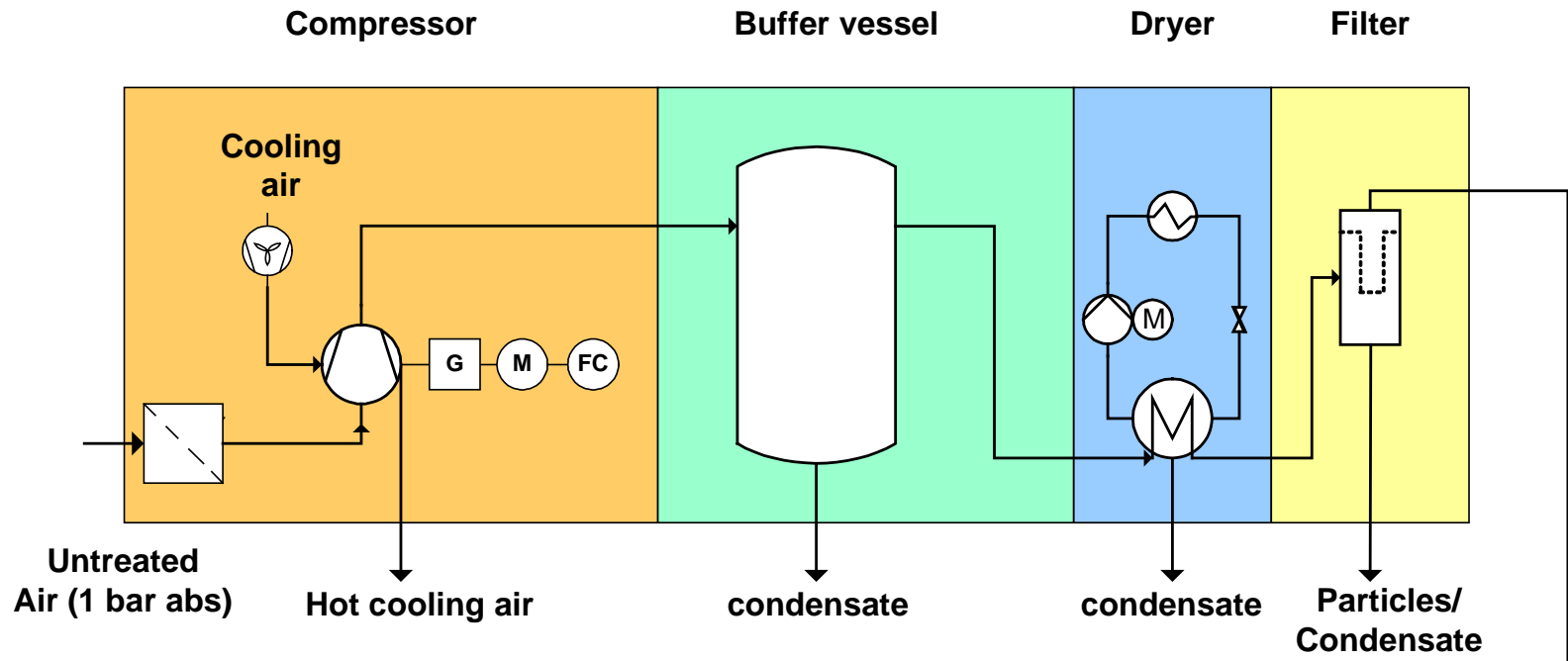

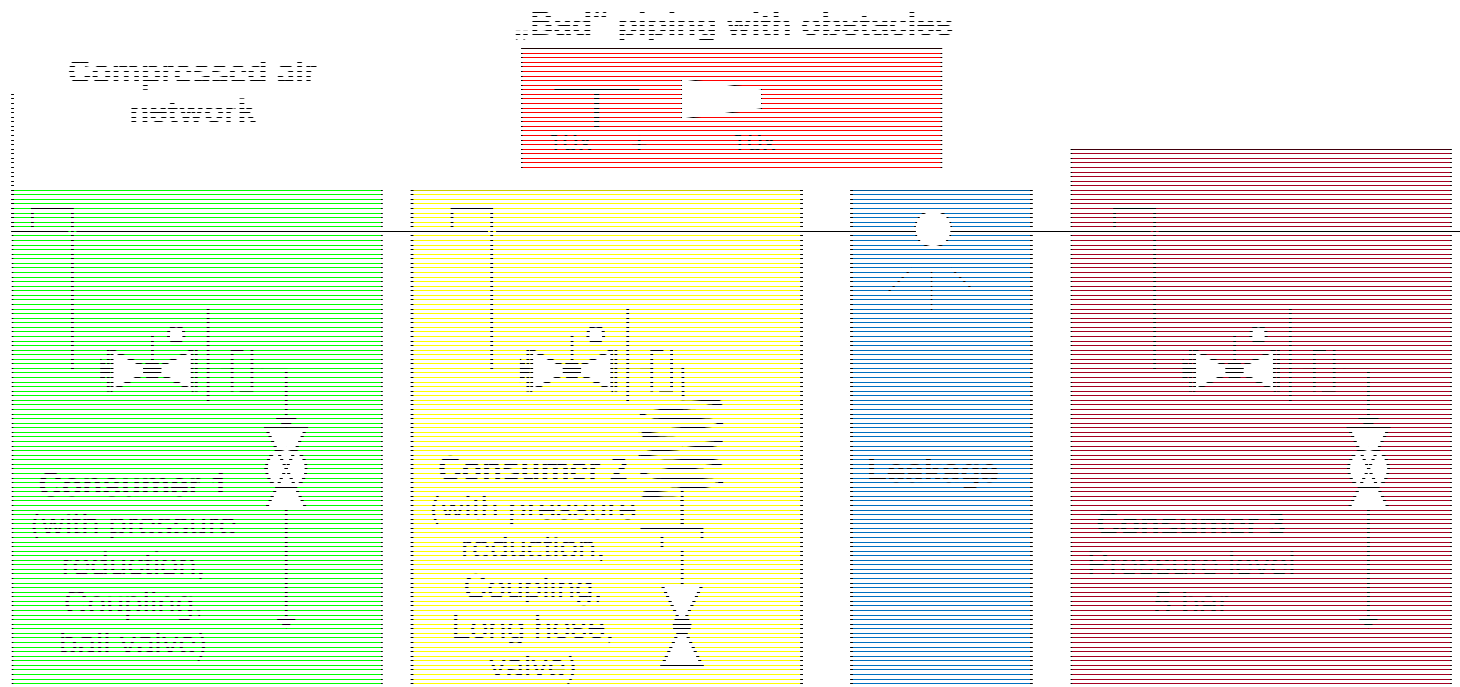
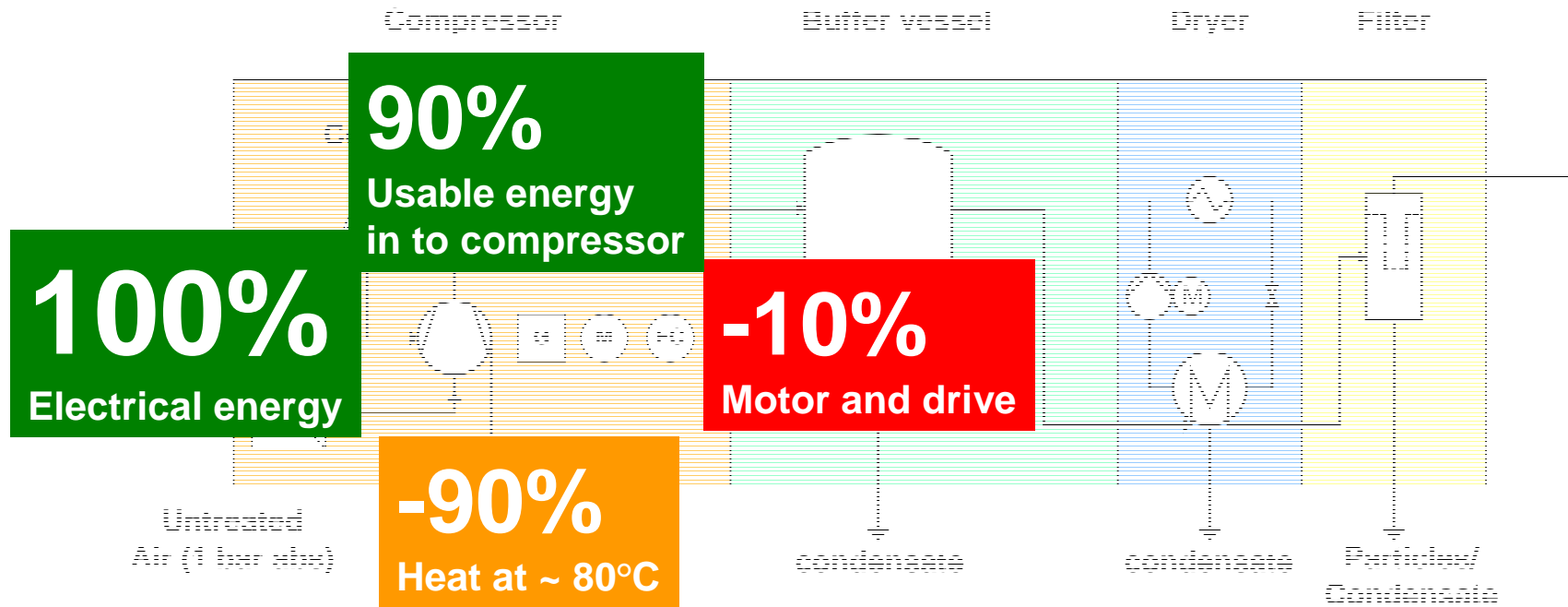

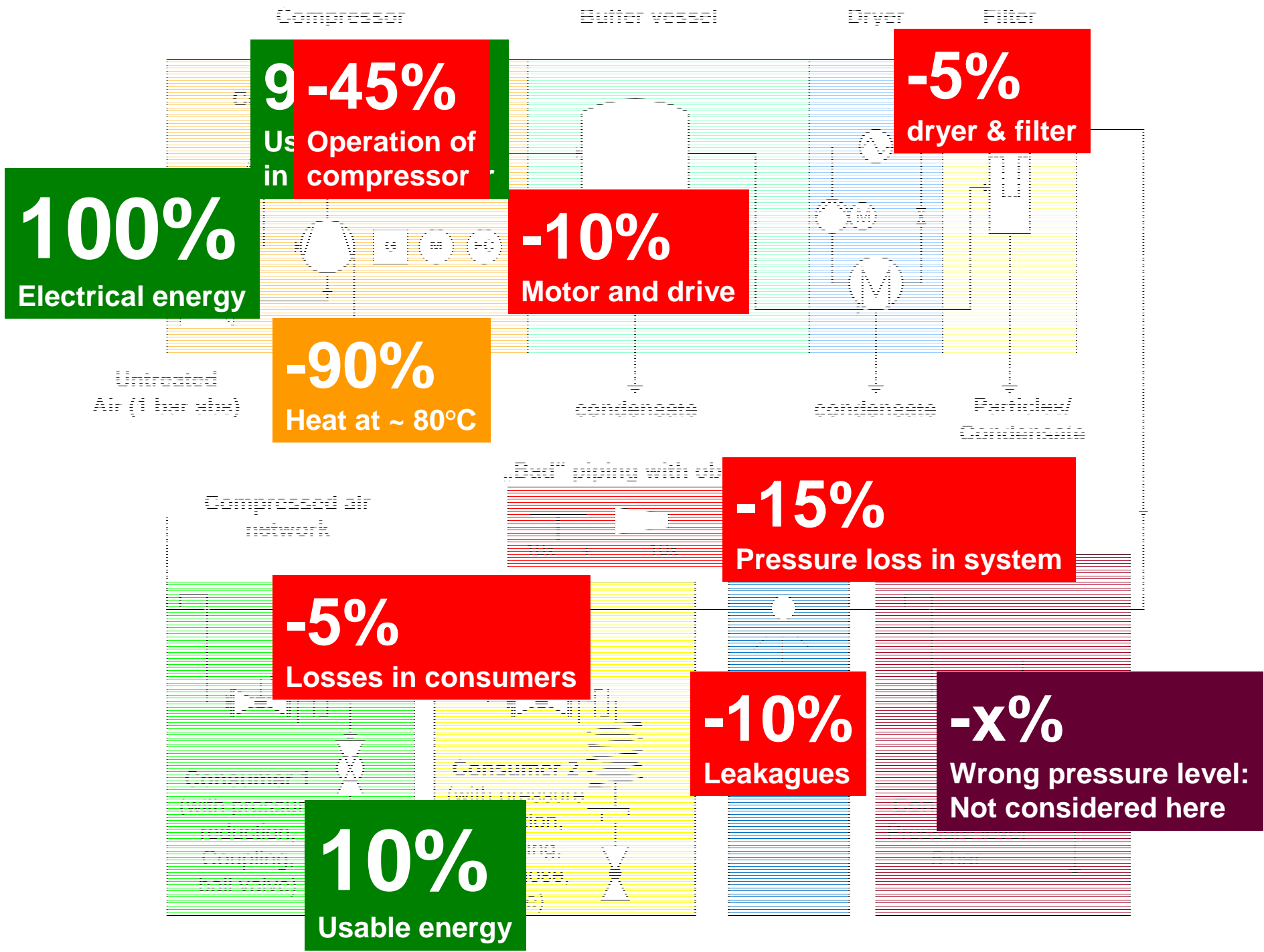

100%
Electrical energy

-45%
Operation of compressor

-10%
Motor and drive

-90%
Heat at ~ 80°C

-5%
dryer & filter

-15%
Pressure loss in system

-5%
Losses in consumers

-10%
Leakages

-x%
Wrong pressure level:
Not considered here

10%
Usable energy

3) Energy Efficiency: How?

Example 1: compressed air

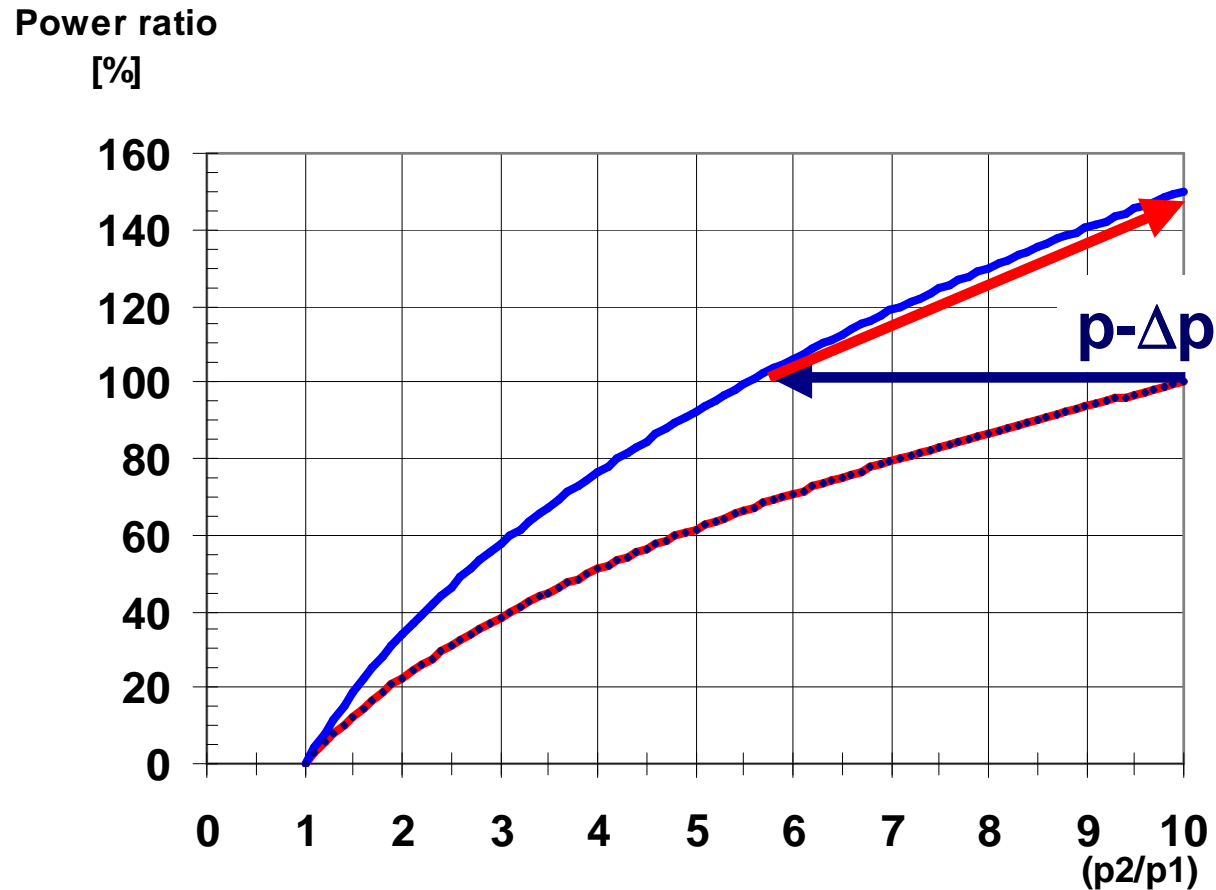

Example:

Pressure losses in system (obstacles, leakages, etc., see above)

account for more power need

-> How good is my system? Measure? Benchmark?

Power [kWh per (m³/min)]

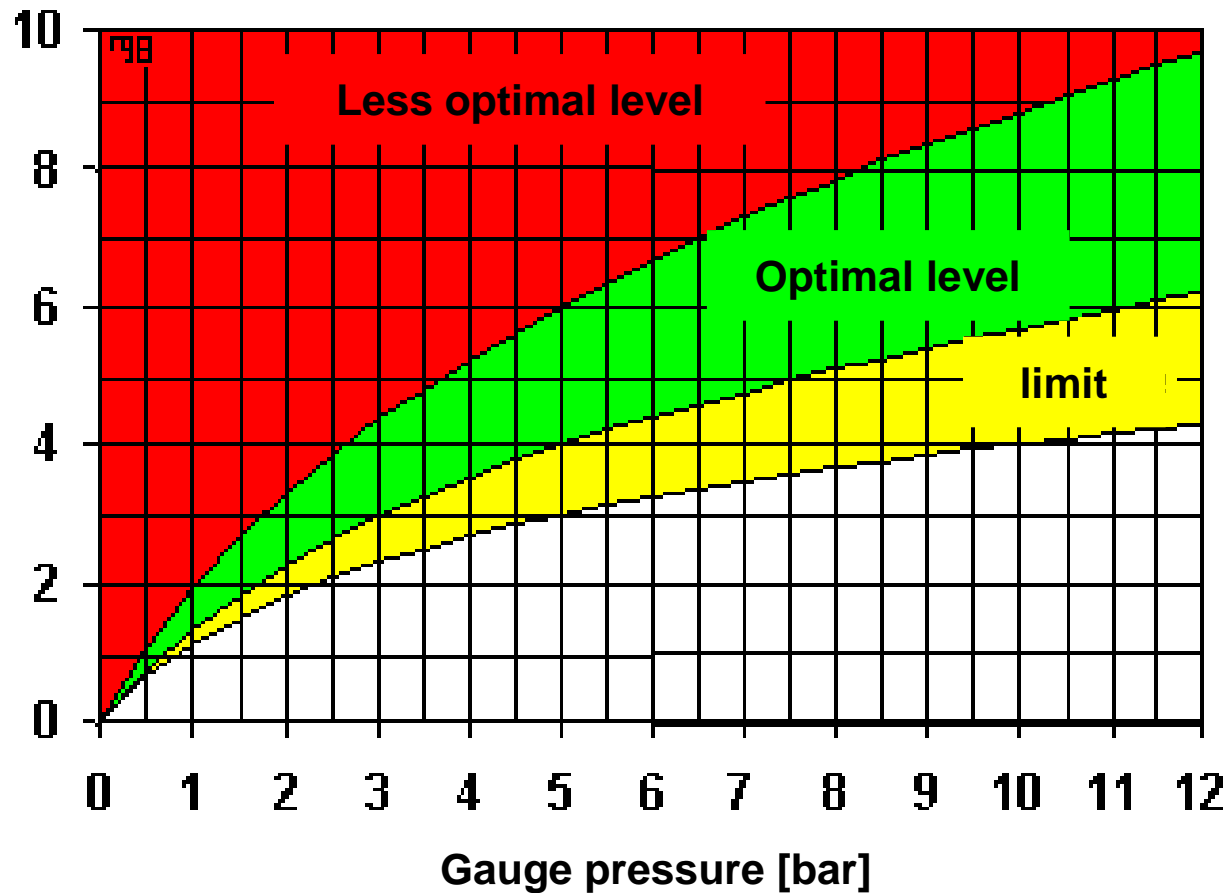

Benchmarking for compressed air systems

(Source: <http://www.energie.ch/>)

3) Energy Efficiency: How?

Example 1: compressed air

Power [kWh per (m³/min)]

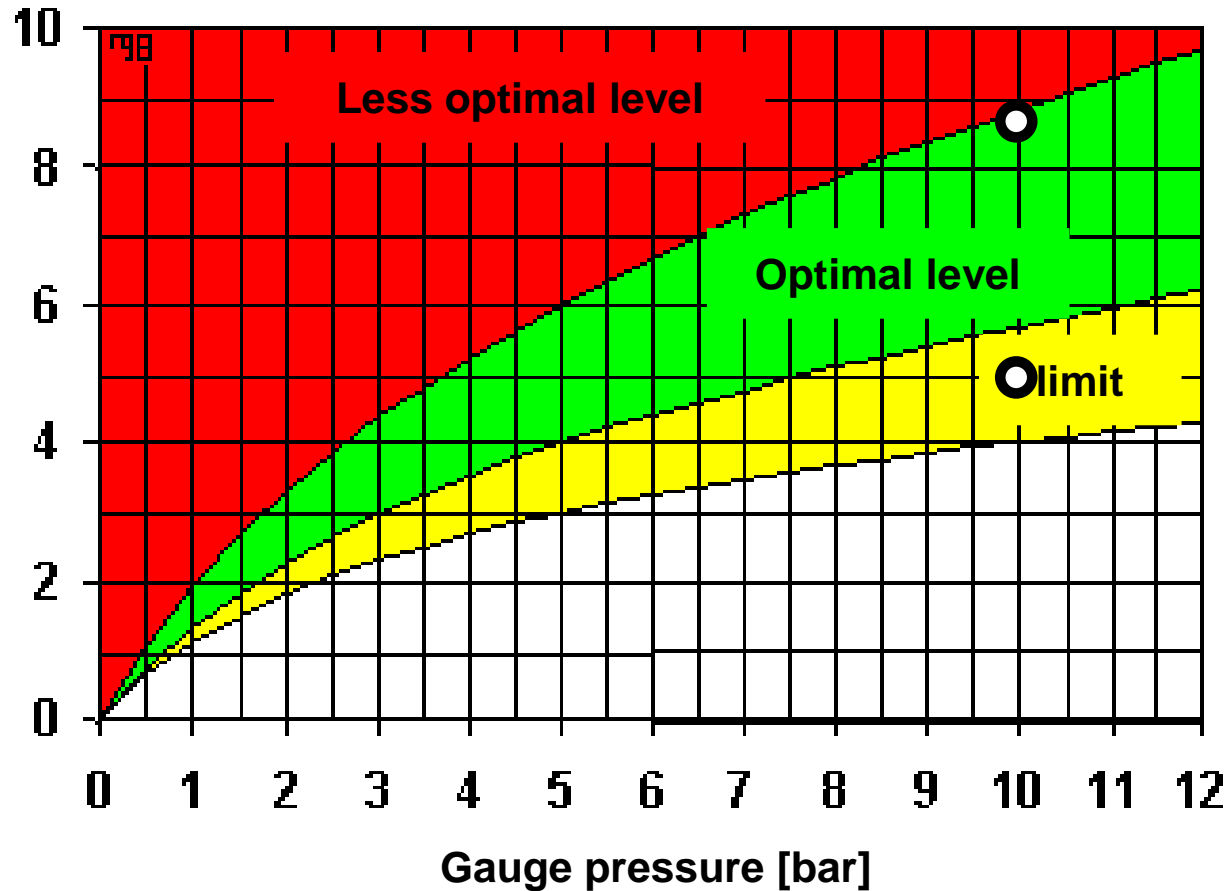

Your
Optimization
potential?

Benchmarking for compressed air systems

(Source: <http://www.energie.ch/>)

Optimization of compressed air systems:

- ✓ Optimize operation of compressor
- ✓ Controls of compressor
- ✓ Use waste heat of compressor where possible
- ✓ Optimize filter and dryer (e.g. exchange filter regularly)
- ✓ Reduce obstacles in pipe system
- ✓ Reduce leakages
- ✓ Use efficient consumers
- ✓ Train the operators: increase awareness!

Typical Life cycle cost of a compressed air system

- Life-Cycle Costs
- Total Cost of Ownership

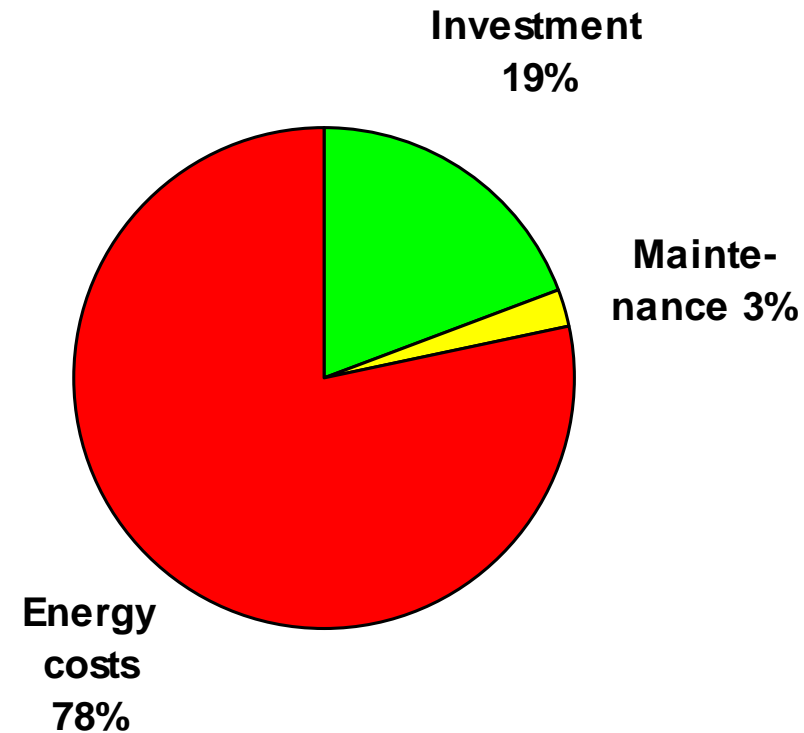

Use life-cycle costs as basis for decisions, not total investment

Source: Bayrisches Landesamt für Umwelt

3) Energy Efficiency: How?

Example 2: Production Planning

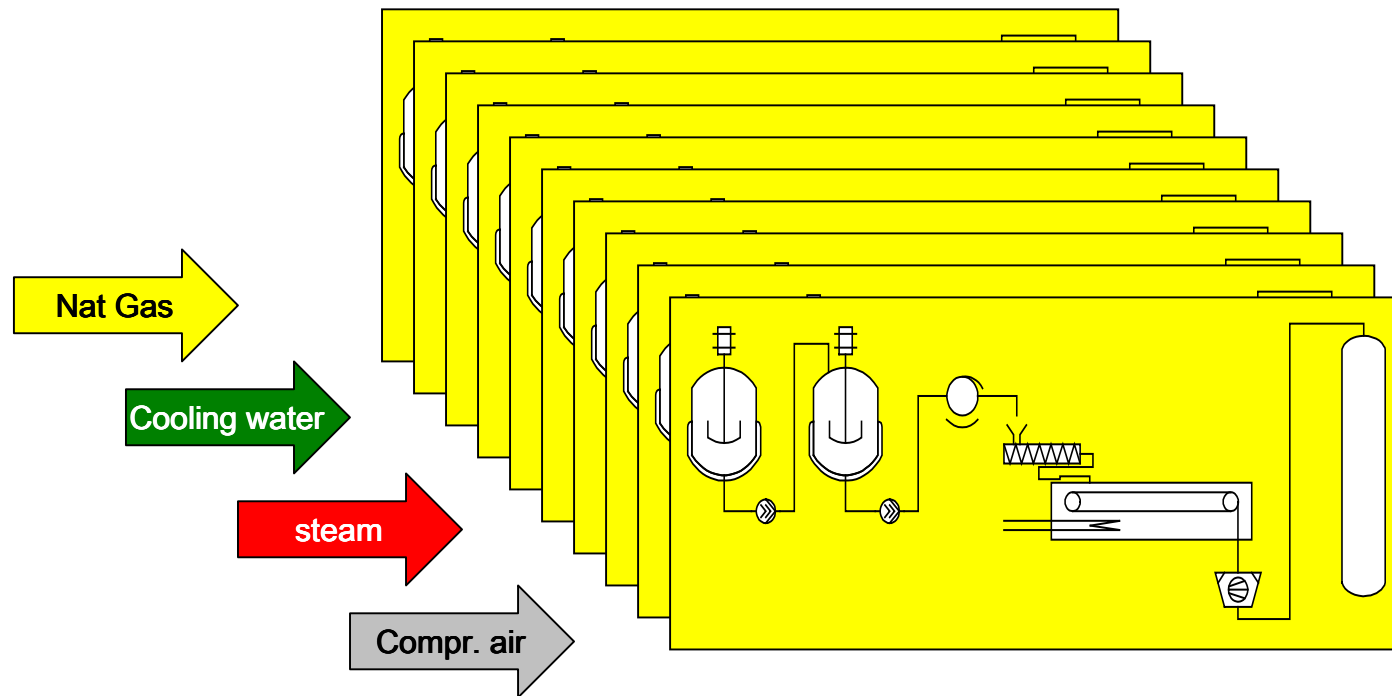

- Use of utilities/ energies
 - natural gas
 - cooling water
 - steam
 - compressed air

- How much?
- When?
- Base load?
- Peak load?
- Efficient use of equipment?

3) Energy Efficiency: How?

Use of utilities in batch plant

1) Measure/ Record!

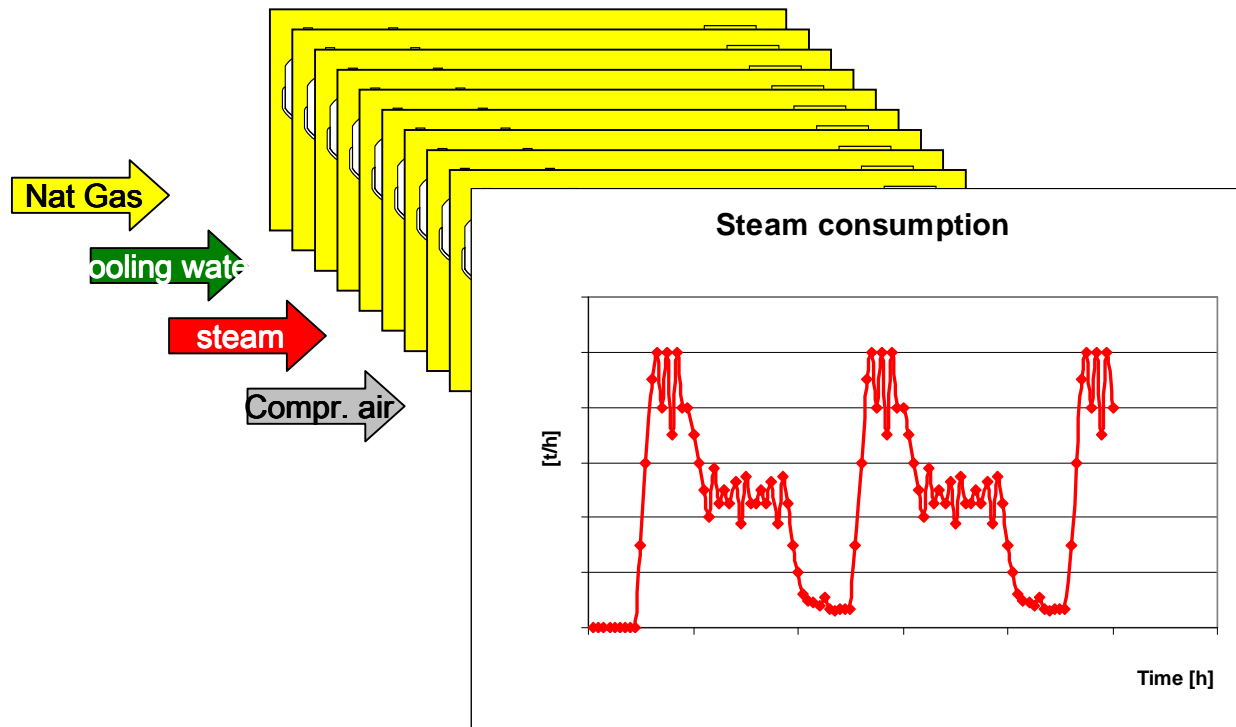

Measurement gives: high peak load

- Equipment is too big!
- Equipment utilization and specific costs high!
- Equipment design is inefficient!
- Peak-load price is very expensive

3) Energy Efficiency: How?

Use of utilities in batch plant

- 1) Measure/ Record!
- 2) Analyze

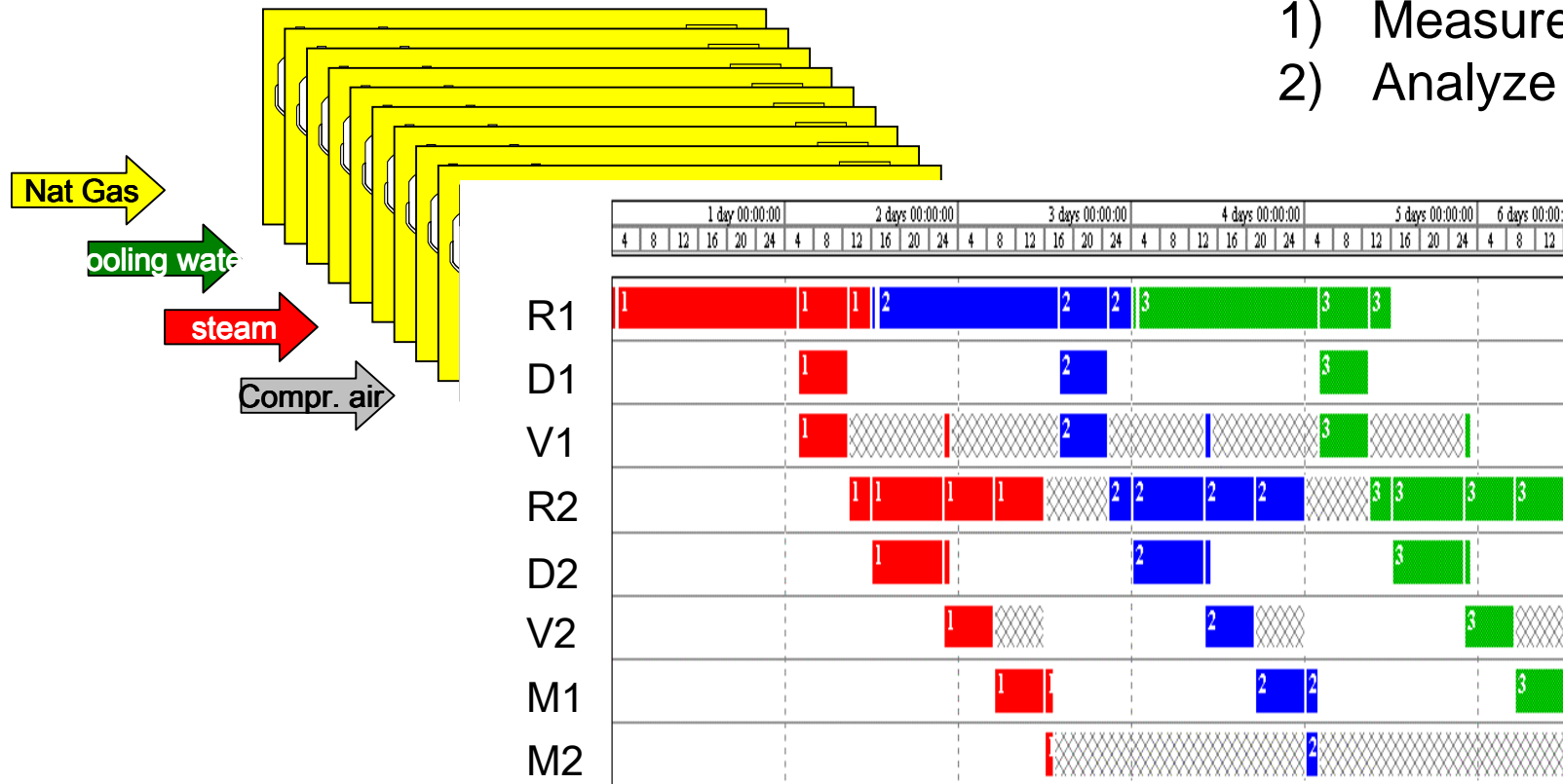

Perform capacity analysis (i.e. batch mass balance):

- Detailed view of process possible
- Equipment utilization
- Basis for optimization

3) Energy Efficiency: How?

Use of utilities in batch plant

- 1) Measure/ Record!
- 2) Analyze
- 3) Optimize

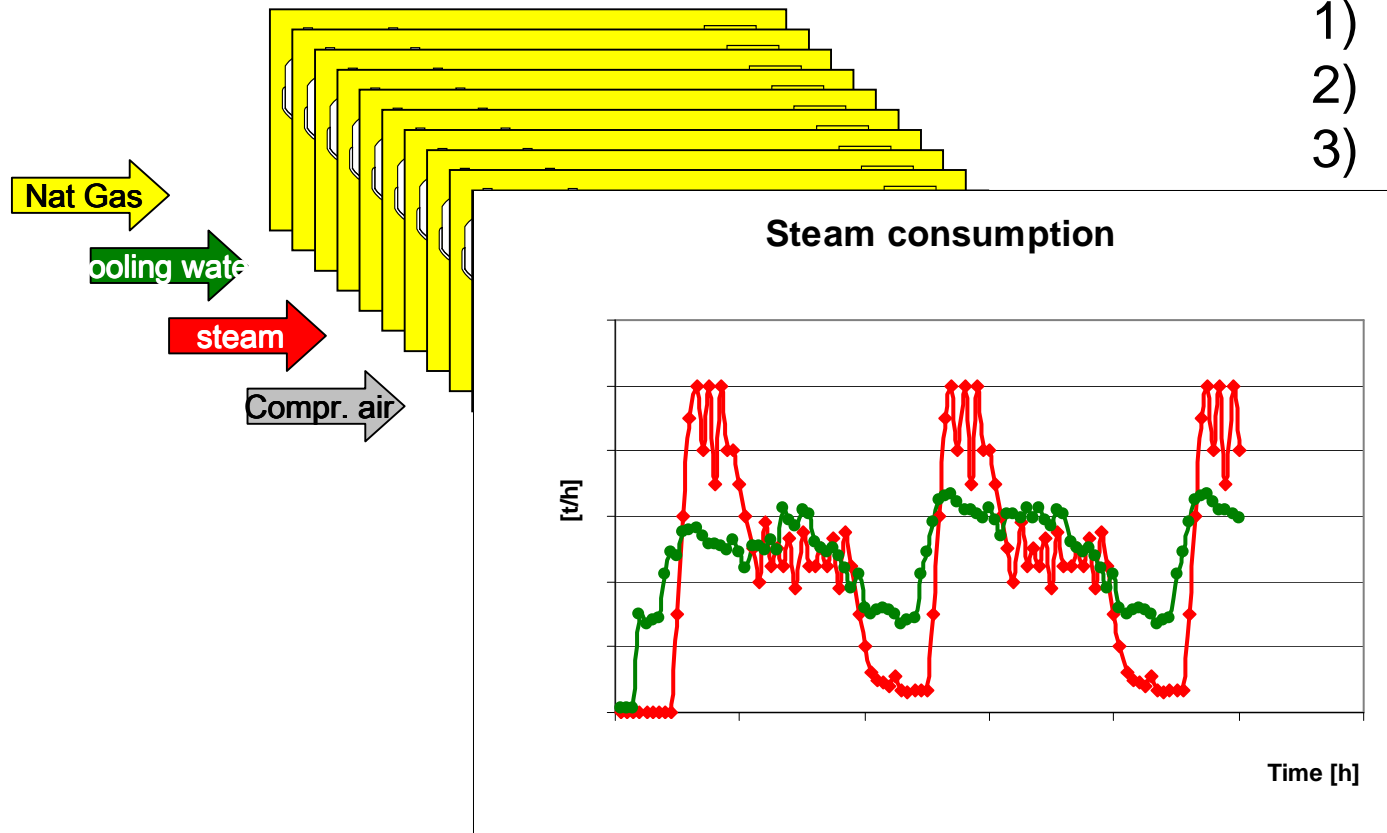

Optimized process:

- Better equipment utilization
- Better energy efficiency of pumps and heat exchangers
- No more peak load: reduced energy price

3) Energy Efficiency: How?

Example 3: Optimization Projects (=Energy Audit?)

3) Energy Efficiency: How?

Optimization Projects to increase energy efficiency:

- People involved: Decision makers, specialists, engineers and internal energy consultants
- These people know best about weak points and strength
- about their problems/ the areas of optimization
- Why use external assistance?
- Audit = „one of these typical consulting projects“ ???

3) Energy Efficiency: How?

Optimization Projects to increase energy efficiency:

- There exist long “punsh lists”
“for years we wanted to...”

But it is often unknown/ not available:

- o Time to find and analyze optimization potentials
- o Time to prioritize actions
- o Time to define projects
- o Time to implement new measures.

3) Energy Efficiency: How?

Optimization projects = Energy audits answer:

- ✓ How much energy can be saved
- ✓ What is the best available technology
- ✓ How to evaluate optimization potentials
- ✓ How to implement new technologies
- ✓ How to sensibilise employees

Together with people involved

3) Energy Efficiency: How?

Optimization projects/ Energy audits: procedure

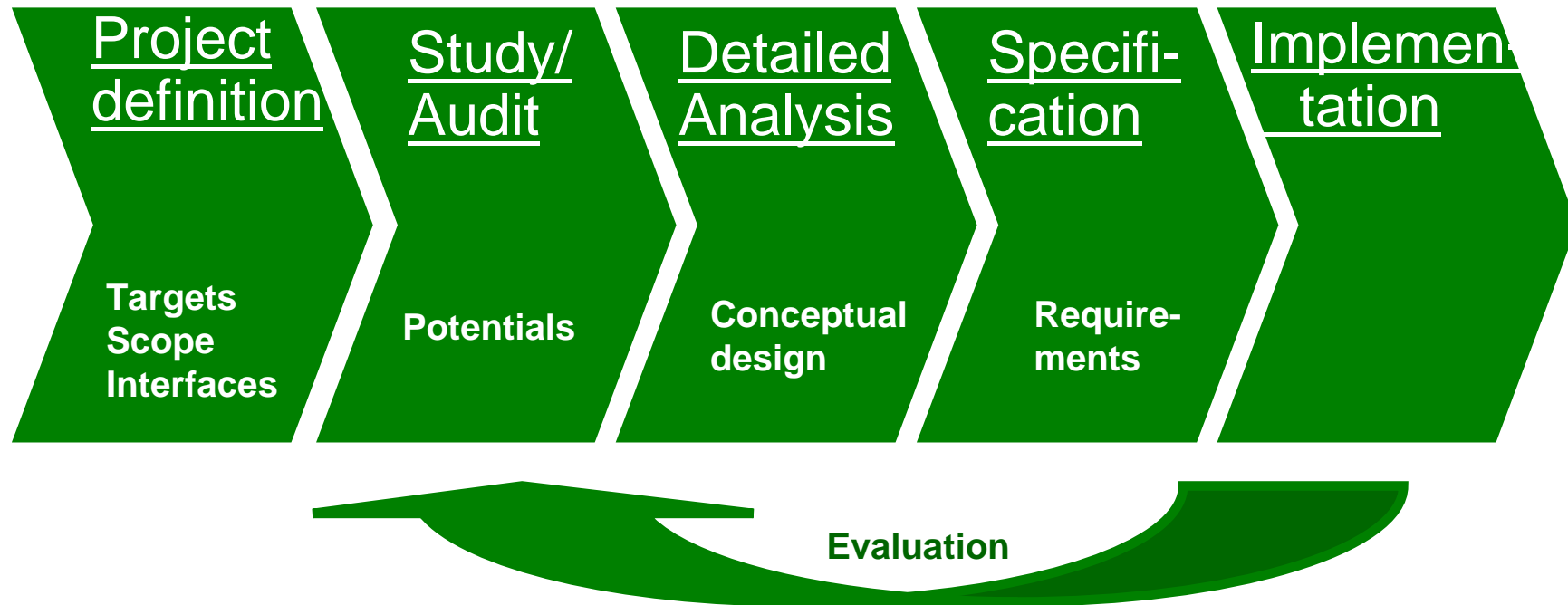

3) Energy Efficiency: How?

Example 1: compressed air

Tabelle 1: Interne Verzinsung in Abhängigkeit von der Nutzungsdauer und in Relation zur Amortisationszeit

geforderte Amortisationszeiten (Jahre)	Interne Verzinsung in % pro Jahr ¹⁾							
	Anlagennutzungsdauer (Jahre)							
	3	4	5	6	7	10	12	15
2	24%	36%	41%	46%	47%	49%	49,60%	50%
3	0%	13%	20%	26%	27%	31%	32%	33%
4		0%	8%	13%	17%	22%	23%	24%
5			0%	8%	10%	10%	17%	18,60%
6		unrentabel		0%	4%	10,60%	12,60%	14,60%
8						4,60%	7%	8%

¹⁾ unterstellt wird eine kontinuierliche Energieeinsparung über die gesamte Anlagennutzungsdauer

abgeschnittene rentable Investitionsmöglichkeiten: Chancen des Contracting

Quelle: DOE, 1982

IRR, Internal Rate of Return
Economic value added



3) Energy Efficiency: How?

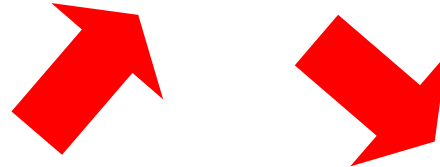

3) Energy Audits: Fields for Optimization

- **Process technology**
 - Heat integration
 - **Waste heat recovery**
 - Thermal & Mechanical process engineering
 - Reaction engineering
 - Process intensification
- **Component Efficiency**
 - Facilities for Heating and Cooling
 - Heat Exchangers
 - Dryers
 - Mills
 - Agitators, Kneaders
 - Pumps
 - **Compressors, vacuum pumps**
 - Lifting, conveying and transport
 - Motors and Drives
 - **Lifecycle costs / total cost of ownership**
- **Usage of energy sources**
 - cogeneration
 - steam (pressure levels)
 - condensate return and reuse
 - water (river, city, cooled)
 - **compressed air**
 - natural gas
- **Production buildings**
 - Insulation
 - HVAC (heating, ventilation & air conditioning)
 - lighting
- **Process control and operation**
 - Automation
 - Production planning
 - Information management
 - Energy management
- **Management**
 - Energy contracting
 - New methods for project financing

Nr.	Field of optimization	Current Status	Measure	Potential	Tasks for detailed analysis	Implementation [months]	Estimated benefit [€/a]	Estimated Investment Costs [€]	Amortisationszeit [a]	Service life [Years]	Renability [%/a]
1	Process Technology										
1	Component efficiency	Pumps are operated in bypass mode	Install new drive with FC, automate, change piping	Reduce energy consumption by 30%	Conceptual design and cost estimation	6	4.200	9.300	2,2	5	20%
4	Supply and Usage of Energy Sources	compressed air									
5	Production Buildings										
2	Process Control and Operation	Parallel operation of dryers causes peak load and inefficiency of equipment	Change production planning, implement visualization	Increase equipment efficiency by 10%, reduce peak load costs	Perform Capacity analysis	4	#####	#####	1,1	6	46%
7	Management-tools										

3) Energy Efficiency: How?



Nr.	Field of optimization	Current Status	Measure	Potential	Tasks for detailed analysis	implementation [months]	Estimated benefit [€/a]	Estimated Investment Costs [€]	Amortisationszeit [a]	Service life [years]	Rentability [%/a]
1	Process Technology										
1	Component efficiency	Pumps are operated in bypass mode	Install new drive with FC, automate, change piping	Reduce energy consumption by 30%	Conceptual design and cost estimation	6	4.200	9.300	2,2	5	20%
4	Supply and Usage of Energy Sources	compressed air									
5	Production Buildings										
2	Process Control and Operation	Parallel operation of dryers causes peak load and inefficiency of equipment	Change production planning, implement visualization	Increase equipment efficiency by 10%, reduce peak load costs	Perform Capacity analysis	4	#####	#####	1,1	6	46%
7	Management-Tools										

Systematic analysis gives potentials and priorities

- at an early stage
- for low cost

4) Energy Efficiency: Why else?

- 1) Motivation and Outline
- 2) Energy Efficiency: Why?
- 3) Energy Efficiency: How?
- 4) Energy Efficiency: Why else?
- 5) Summary



- Marktdaten
- Transparenz
- EEX
- Downloads
- Teilnehmer werden
- Presse

12,49 €/MWH PHELIX DAY PEAK: 49,19 €/MWH MARKTDATEN: 17.10.2009 SWISSIX DAY BASE: 67,50 €

EU Emission Allowances | Preise und Handelsvolumen | 07.10.2009 - 16.10.2009 | European Energy Exchange

- emissionsrechte
- EU Emission Allowances | Spotmarkt

Tabelle Chart

Einstellungen 2009-10-16 Anzeigen

Marktdaten als RSS-Feed

	Mi, 07.10.	Do, 08.10.	Fr, 09.10.	Mo, 12.10.	Di, 13.10.	Mi, 14.10.	Do, 15.10.	Fr, 16.10.	
Gesamt EEX	13,66	13,34	13,65	14,26	14,31	14,47	14,23	-	€/t CO ₂
	50.000	10.000	-	5.000	15.000	50.000	-	-	t CO ₂
Carbix	13,79	13,51	13,53	13,88	14,30	14,44	14,22	14,27	€/t CO ₂
	-	-	-	-	-	-	-	-	t CO ₂
OTC	-	-	-	-	-	-	-	-	t CO ₂

Seite drucken

4) Energy Efficiency: Why else?

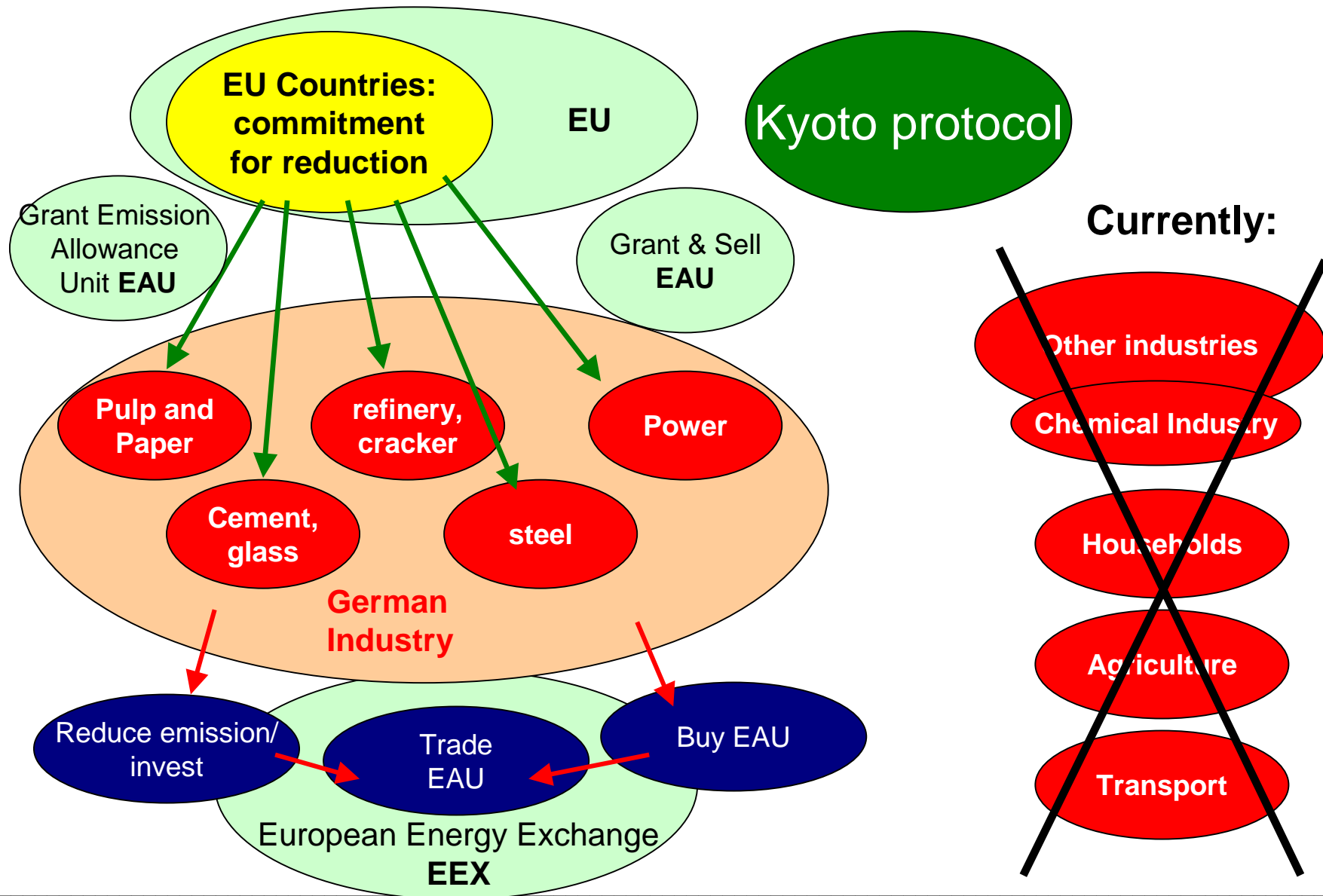

4) Energy Efficiency: Why else?

Third phase of emission trading from 2013:

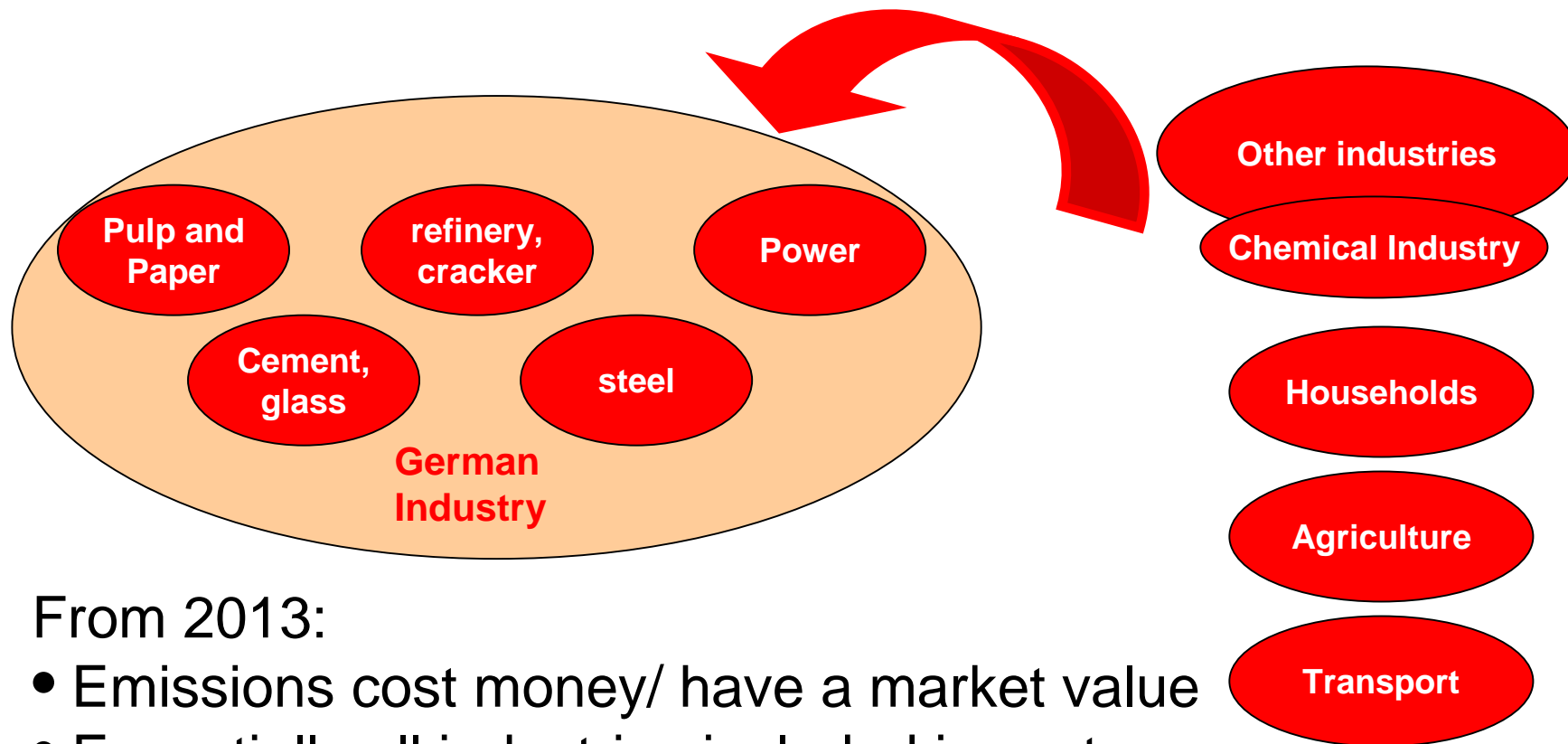

From 2013:

- Emissions cost money/ have a market value
- Essentially all industries included in system

5) Summary

Energy Efficiency

- Can decrease Spains dependence on fossil fuels
- Projects are therefore funded by the Government
- Earns Money
- Reduces CO₂ emissions

Further information and detailed references, examples under

- <http://prof.beuth-hochschule.de/bungert/>
- <http://www.ib-bungert.de>